

TITLE

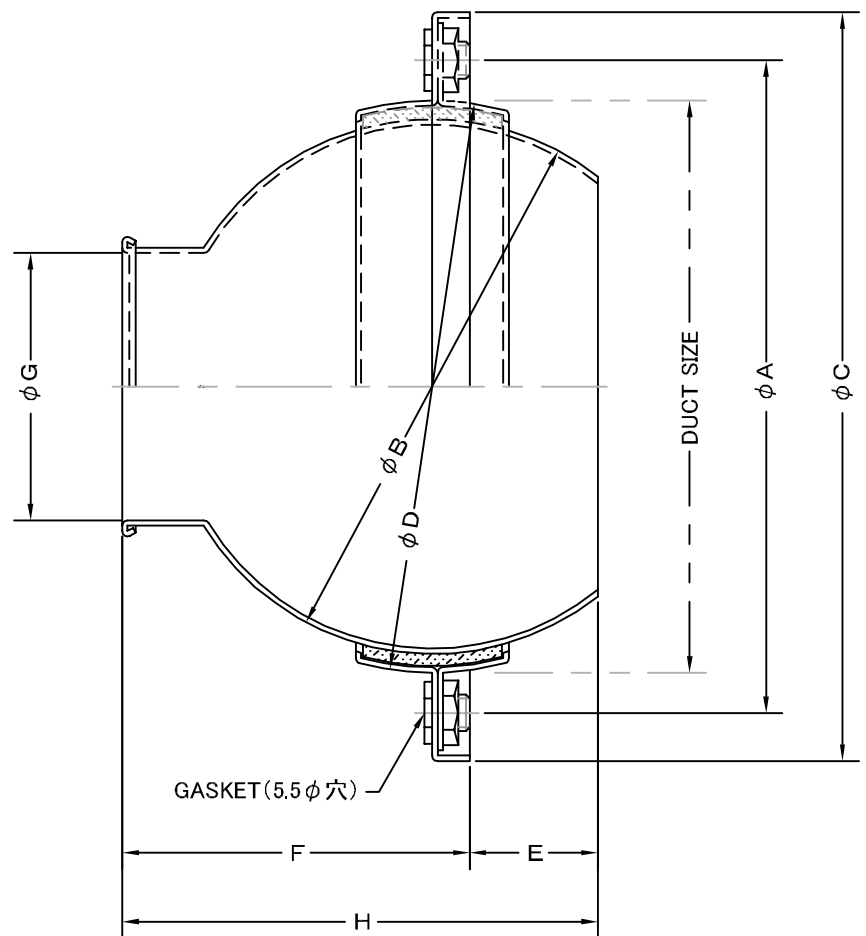
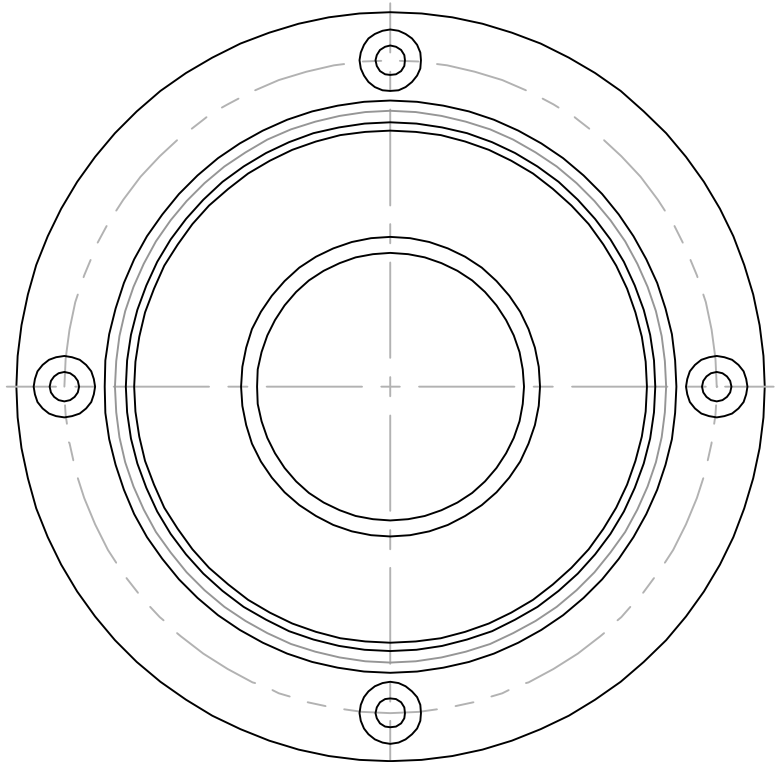

SIZE	A	B	C	D	E	F	G	H	DUCT OPENING	GASKET数	Q'TTY
No. 3	97	75	115	82	17	53	38	70	85	3	
No. 3.5	107	85	125	92	21	58	43	79	95	3	
No. 4	122	100	140	107	24	65	50	89	110	4	
No. 4.5	137	115	155	122	29	73	58	102	125	4	
No. 5	152	130	170	137	33	82	65	115	140	5	
No. 6	172	150	190	158	38	94	75	132	160	5	
No. 7	213	178	231	185	38	111	90	149	190	5	
No. 8	232	200	250	204	44	120	100	164	208	5	
No. 10	304	267	324	276	50	174	140	224	280	5	
No. 12	342	305	363	314	63	200	165	263	318	5	
No. 14	342	305	363	314	60	185	190	245	318	5	
No. 16	451	410	470	419	92	248	230	340	425	8	
No. 18	511	470	535	479	95	295	260	390	486	8	
No. 20	511	470	535	479	95	295	310	390	486	8	

材質	ALUMINUM	
表面仕上	銀色アルマイト仕上ゲ	
図面名称	アルミ製パンカールーバー (シャッター無し)	型式 PK-E
承認	検図	製図
H. T	H. K	H. A
設計	設計	尺
K. N	K. N	度
作成日	2007-02-01	FREE
図番	SI591090S	
 西邦工業株式会社 SEIHO		